



Handling Package electronic XL version

Item no. 26084

Handling package electro XL: This package enables you to change the coating batch within a very short time and thus make your production even more economical. With the included electro-hydraulic RoRo-Mobil with set-down station, the second substrate table, which is also included, can be exchanged as quickly as possible.

Contact experts

 +49 2405 44 70 122

 coatingtechnology@cemecon.de

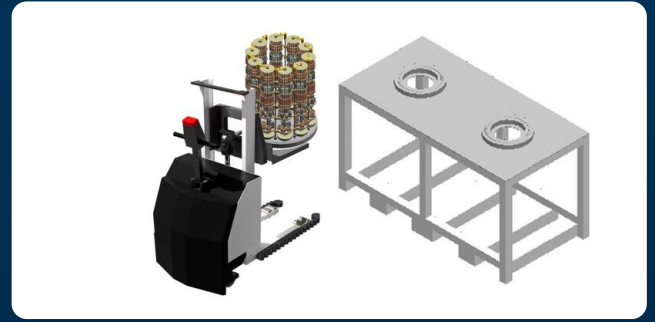

Specifications

Coating unit	CC800® XL
Coating procedure	Coating
Tool type	Shank tools Indexable inserts
Process step	Transportation

Scope of delivery:

- 1 Electric pallet truck in special design
- 1 Substrate table ø650 - 10s
- 1 Parking station 650er table