

Handling package electronic ML version

Item no. 26085

Handling package electro ML: This package enables you to change the coating batch within a very short time and thus make your production even more economical. The package includes an electro-hydraulic RoRo-Mobil with set-down station. This allows the second substrate table, which is also included, to be changed as quickly as possible.

Contact experts

+49 2405 44 70 122

coatingtechnology@cemecon.de

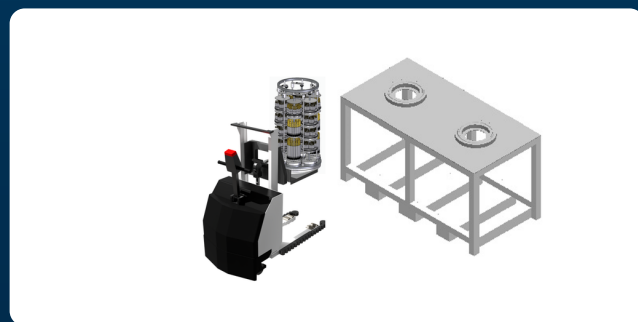

Specifications

Coating procedure

Process step

Tool type

Coating unit

Coating

Transportation

Indexable inserts

Shank tools

CC800®HiPIMS

CC800®/9 ML

Scope of delivery:

- 1 Electric pallet truck in special design
- 1 Substrate table ø400 - 6s/9ML
- 1 Parking station 650 table with adapter for substrate table ø400 - 6s/9ML